

MATERIAL AND FINISH:

Insulator: Polycarbonate, UL-94V-0 rated
 Contacts: Brass, Nickel plated

ELECTRICAL SPECIFICATIONS:

Inlet Current rating: 10 A 
 Fuse Holder Current rating: 6A  10A 
 Voltage rating: 250 VAC
 Insulation resistance:
 100 Mohm min. at 500 VDC
 Dielectric withstanding voltage:
 2000 VAC for one minute

ORDERING CODE:

42R31-3 1 - 3
 1 2 3

1) COLOR

- 1 = BLACK
- 2 = GRAY

2) ELECTRICAL CIRCUIT CONFIGURATION

- 1 = 10A 250V 70°C
2+GROUND 
- 2 = 10A 250V 120°C
2+GROUND 
- 4 = 10A 250V 70°C
2 POLE 

3) PANEL THICKNESS

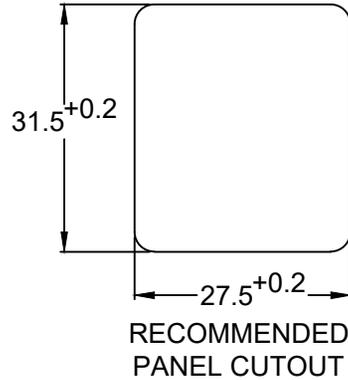
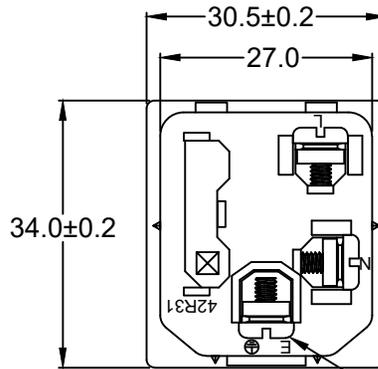

M3x6.0mm
SCREW TERMINALS

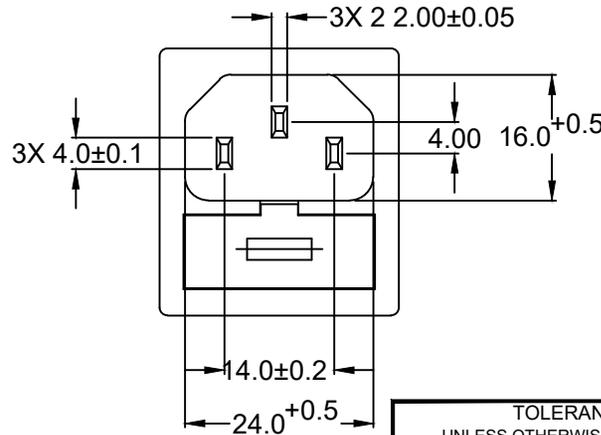
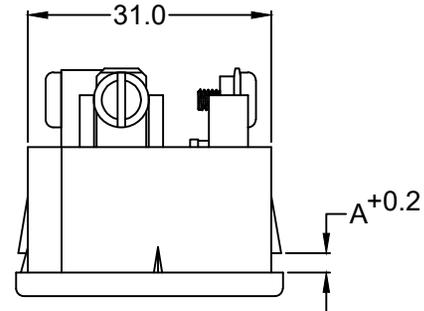
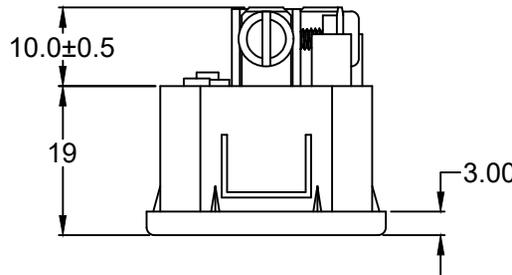

| P/N | A | MAX. PANEL THICKNESS |
|----------------|-----|----------------------|
| 42R31-3X1X-150 | 1.5 | 1.5 |
| 42R31-3X1X-200 | 2.0 | 2.0 |
| 42R31-3X1X-250 | 2.5 | 2.5 |

ADDITIONAL PANEL THICKNESS
AVAILABLE ON REQUEST

| | | | | |
|-----------|--------|----------|-----|------|
| REVISIONS | CHANGE | CHK | CHK | APPR |
| | DATE | 12/15/21 | | |
| | REV | A | | |
| | | | | |

| | | | |
|---|----|-------|----------|
| TOLERANCE UNLESS OTHERWISE SPECIFIED | | | |
| X | ± | 1 | |
| X.X | ± | 0.4 | |
| X.XX | ± | 0.20 | |
| DRAWN BY | GQ | DATE: | 08/30/01 |
| CHECK BY | TD | DATE: | 09/06/01 |
| APPR BY | PB | DATE: | 09/06/01 |

RoHS
COMPLIANT

Power Dynamics, Inc.

Phone: 973 560-0019 Whippany, New Jersey Fax: 973 560-0076

PART: IEC 60320 SINGLE FUSE HOLDER APPL. INLET;
SCREW TERMINALS; SNAP-IN

| | | |
|------------------------|--|--------------|
| PART #: 42R31-3X1X-XXX | | SHEET 1 of 1 |
| SIZE: A | ALL DIMENSIONS FOR REFERENCE ONLY DIMENSIONS ARE IN MILLIMETERS | REV: A |
| SCALE: NTS | | |